

# GRT709

## BORSE LATERALI 35+35LT - SIDE BAGS 35+35LTRS - SACOCHES LATÉRALES 35+35 LITRES SEITENTASCHEN MIT 35 + 35 LITER ALFORJAS LATERALES 35+35 LITROS - SACOS LATERAIS 35 + 35 LITRO

N°	Descrizione	Caratteristiche	Codice	Quantità
1	Borse Laterali 35+35Lt - Side Bags 35+35Ltrs Sacoche Latérales 35+35 - Litres Seitentaschen Mit 35 + 35 Liter Alforjas Laterales 35+35 Litros - Sacos Laterais 35 + 35 Litro	-	GRT709	2(Right,Left)
2	Piastra - Plate Platine - Platte Parrilla - Prato	-	Z7723	2(Right,Left)
3	Supporto Interno - Inner support Support interne - Soporte Interno Innere Unterstützung - Suporte Interno	Sp.2mm	GL3813	8
4	Cavalotto - Retaining clamp Patte de fixation - Abrazadera Halteklammern - Abraçadeira de fixação	16mm	Z9892	8
5	Cavalotto - Retaining clamp Patte de fixation - Abrazadera Halteklammern - Abraçadeira de fixação	18mm TOP	Z9893	4
6	Cavalotto - Retaining clamp Patte de fixation - Abrazadera Halteklammern - Abraçadeira de fixação	18mm LOW	Z9894	4
7	Adattatore - Adaptor Adaptateur - Adapter Adaptador - Adaptador	-	Z9895	4
8	Vite - Screw Vis - Schraube Tornillo - Parafuso	TECF M6x40	640TECF	16
9	Rondella - Washer Rondelle - Scheibe Arandela - Arruela	Ø6	6RON	16
10	Dado - Bolt - Ecrou Mutter - Tuerca - Porca	Dado Autobloccante M6 (H 8mm)	6DADIAU	16
11	Particolari Inclusi nel PL/PLR/PL...CAM Components Included In The PL/PLR/PL...CAM Pièces Incluses Dans PL/PLR/PL...CAM Die Einzelnen Teile Sind Bei PL/PLR/PL...CAM Despieces Incluidos PL/PLR/PL...CAM Explodiu incluído da PL/PLR/PL...CAM	-	-	-

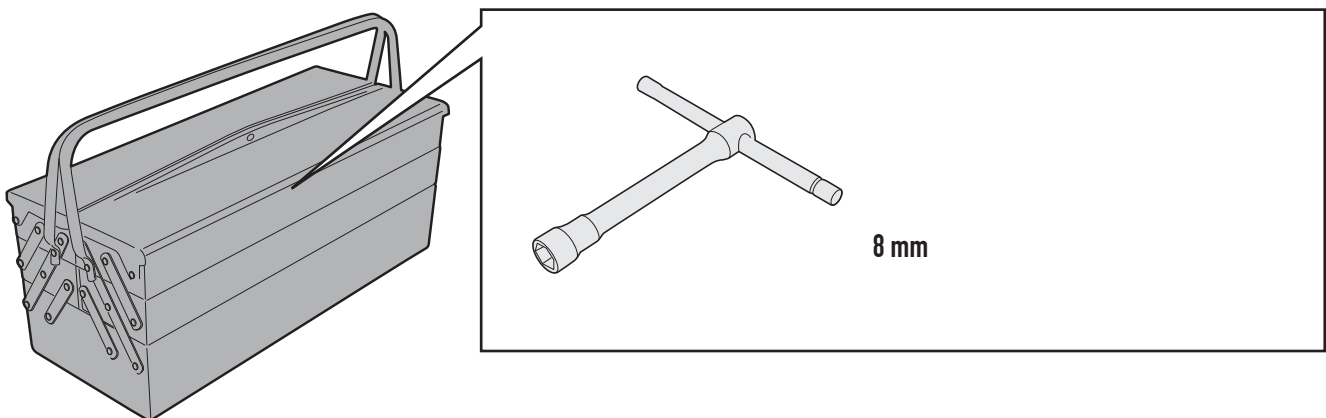

ISTRUZIONI DI MONTAGGIO - MOUNTING INSTRUCTIONS  
INSTRUCTIONS DE MONTAGE - BAUANLEITUNG  
INSTRUCCIONES DE MONTAJE - INSTRUÇÕES DE MONTAGEM

**GIVI**

# GRT709

BORSE LATERALI 35+35LT - SIDE BAGS 35+35LTRS - SACOCHES LATÉRALES 35+35 LITRES SEITENTASCHEN MIT 35 + 35 LITER ALFORJAS LATERALES 35+35 LITROS - SACOS LATERAIS 35 + 35 LITRO



<b>SIZES</b> 	<b>VOLUME</b> <b>35+35lt</b>	<b>REMOVABLE DRY PACK</b> <b>IP65</b> 
<b>REFLECTIVE</b> 	<b>MODULAR</b> 	<b>SHOULDER STRAP</b> 
	<b>BELTS WITH CLIPS</b> 	<b>INNER POCKET</b> 

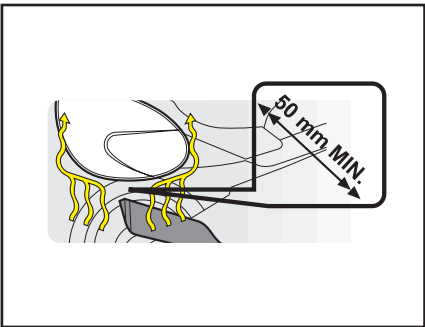

**ATTENZIONE:** Tenere le borse a una ragionevole distanza dalla marmitta. Il calore e i fumi di scarico potrebbero danneggiarle.

**WARNING:** Keep the bags a reasonable distance from the silencer. The heat and the exhaust could damage them.

**ATTENTION:** Tenez les sacoches à une distance raisonnable du système d'échappement. La chaleur et les gaz d'échappement pourraient les endommager.

**ACHTUNG:** Die Taschen in ausreichendem Abstand vom Auspuff andringen, um deren Beschädigung durch Hitze und Abgase zu vermeiden.

**ATENCIÓN:** Mantener las bolsas a una distancia razonable del tubo de escape. El calor y los humos de escape podrían dañarlas.

# GRT709

BORSE LATERALI 35+35LT - SIDE BAGS 35+35LTRS - SACQUES LATÉRALES 35+35 LITRES SEITENTASCHEN MIT 35 + 35 LITER  
ALFORJAS LATERALES 35+35 LITROS - SACOS LATERAIS 35 + 35 LITRO

## MOUNTING ON PL...CAM

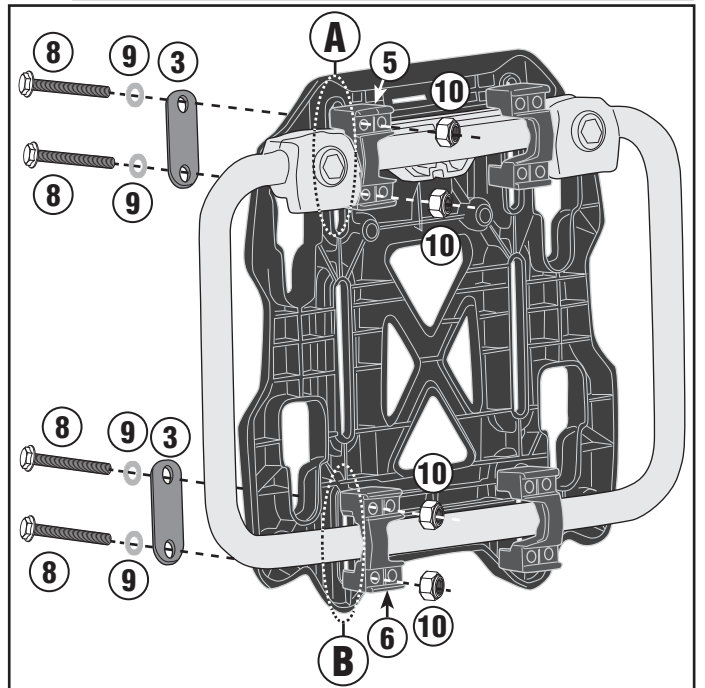
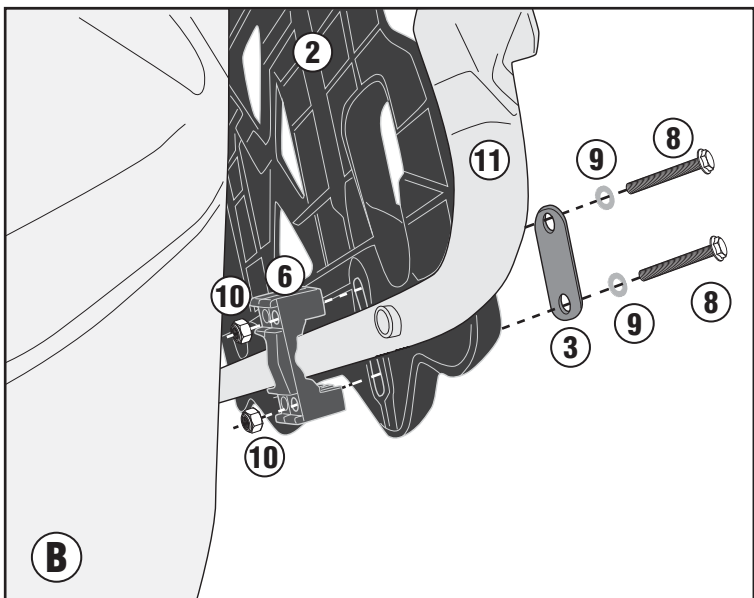
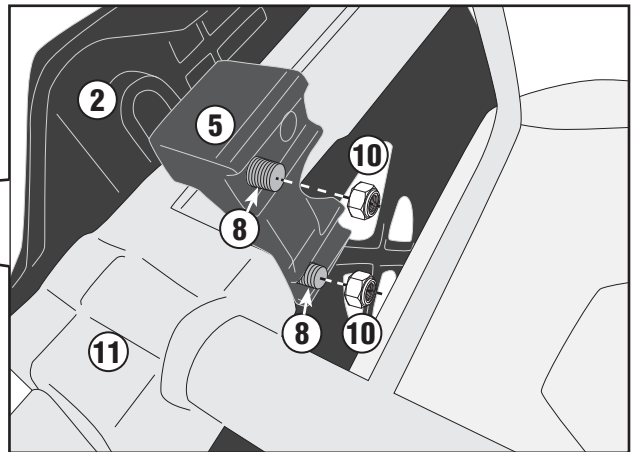
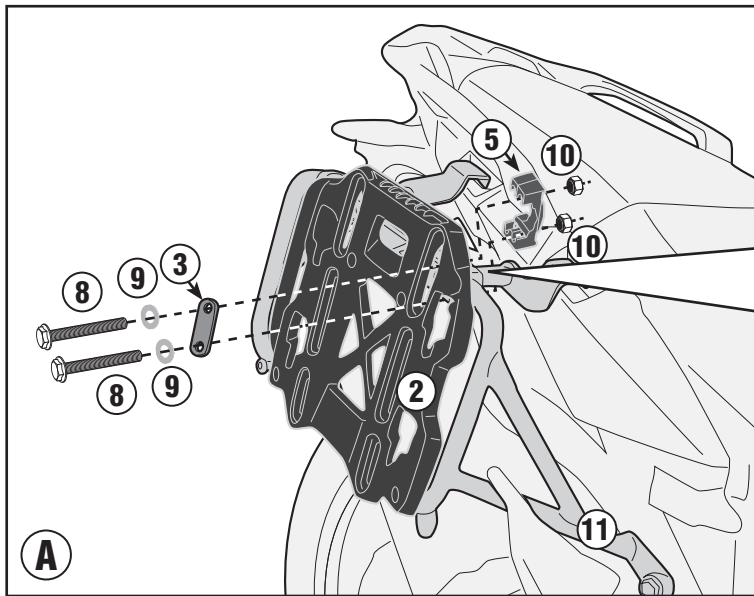
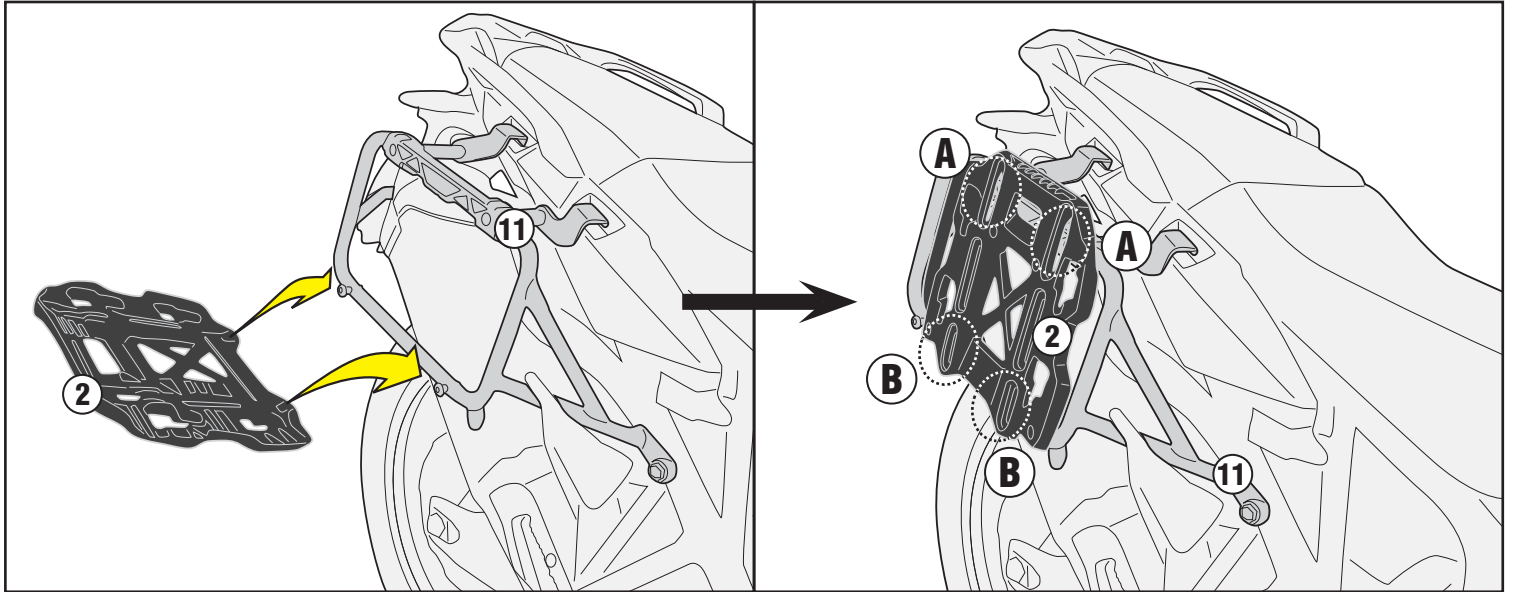

ISTRUZIONI DI MONTAGGIO - MOUNTING INSTRUCTIONS  
INSTRUCTIONS DE MONTAGE - BAUANLEITUNG  
INSTRUCCIONES DE MONTAJE - INSTRUÇÕES DE MONTAGEM

# GRT709

BORSE LATERALI 35+35LT - SIDE BAGS 35+35LTRS - SACOCHES LATÉRALES 35+35 LITRES SEITENTASCHEN MIT 35 + 35 LITER  
ALFORJAS LATERALES 35+35 LITROS - SACOS LATERAIS 35 + 35 LITRO

## MOUNTING ON PL/PLR

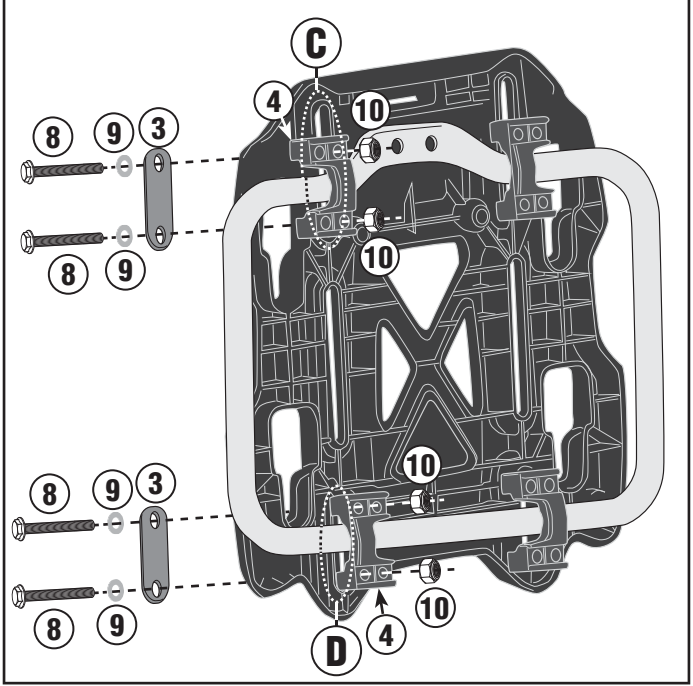
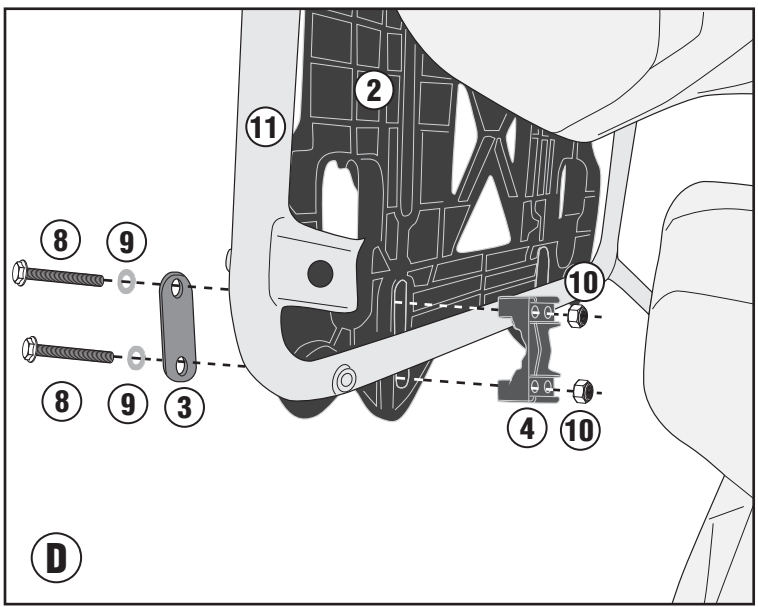
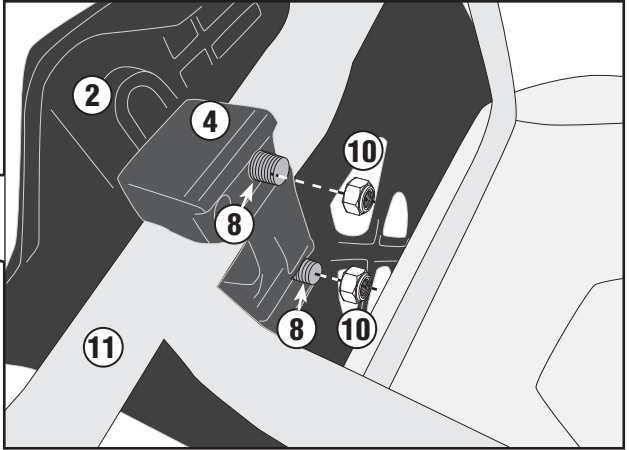
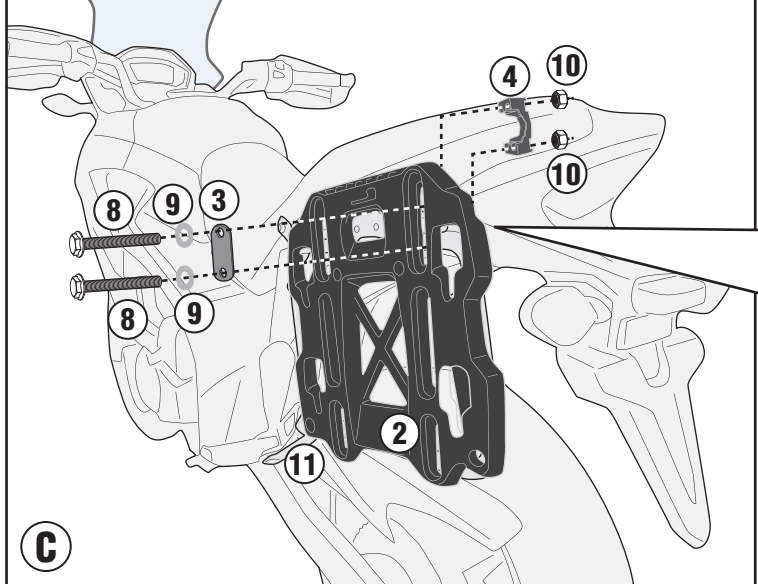
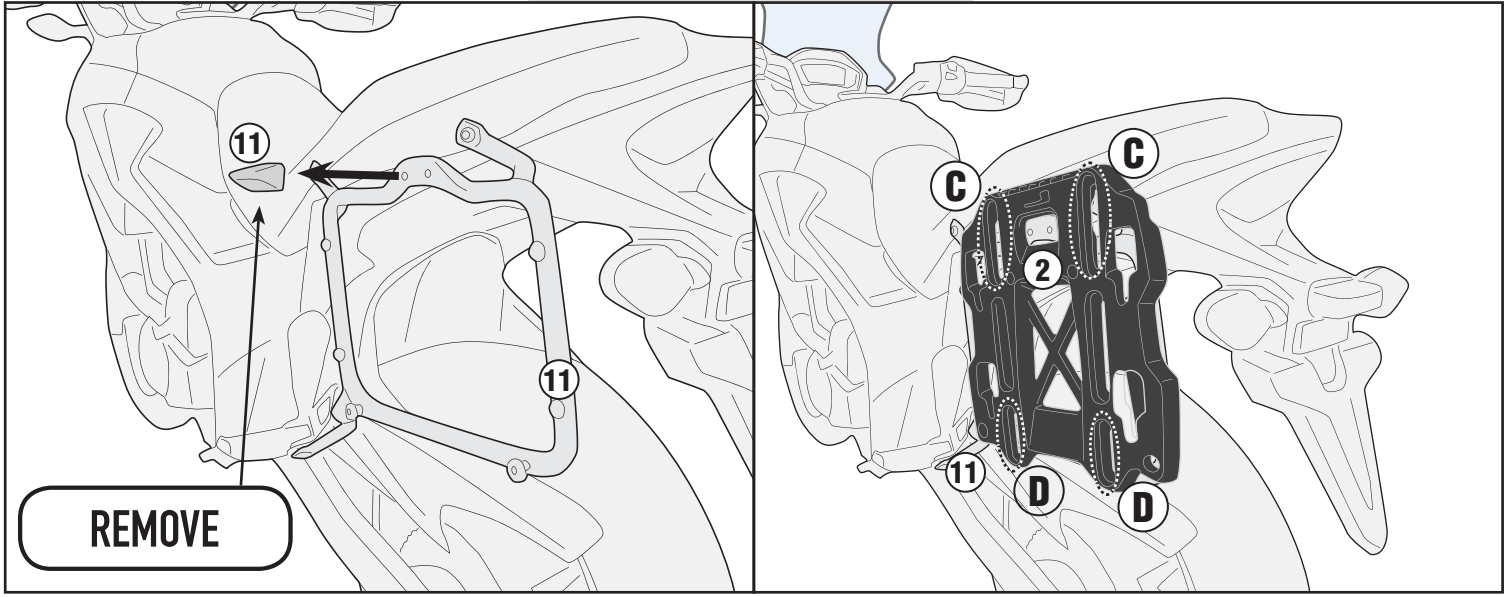

# GRT709

BORSE LATERALI 35+35LT - SIDE BAGS 35+35LTRS - SACOCHES LATÉRALES 35+35 LITRES SEITENTASCHEN MIT 35 + 35 LITER ALFORJAS LATERALES 35+35 LITROS - SACOS LATERAIS 35 + 35 LITRO

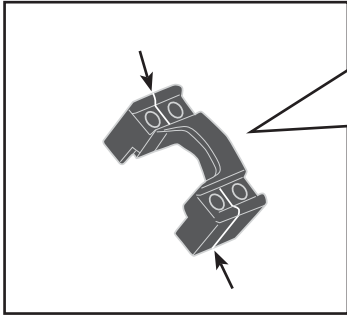

- Nel caso in cui il cavallotto faccia interferenza con altri componenti, è possibile togliere la parte eccedente premarcata con l'aiuto di un seghetto.
- Should the retaining clamp be incompatible with other components, remove the (pre-marked) excess with a hacksaw.
- Si le cavalier touche d'autres composants, il est possible de couper la partie excédentaire pré-marquée à l'aide d'une scie à métaux.
- En caso de que la puente cree interferencia con otros componentes, se podrá eliminar la parte que excede premarcada con una sierra.
- Sollte die Bügelklemme mit anderen Komponenten nicht kompatibel sein, schneiden Sie den überschüssigen Teil (vormarkiert) mit einer Säge ab.
- Caso a abraçadeira de fixação crie interferência com outros componentes, será necessário cortar a parte excedente pré-marcada com uma serra.

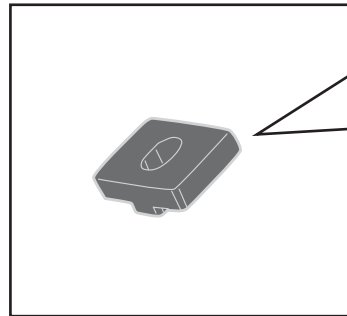

- Adattatore da utilizzare nel caso in cui si montino le GRT709 su telai non Givi e ci sia la necessità di azzerare dei giochi tra gli elementi.
- Adapter to be used if the GRT709 is mounted on non-Givi frames and there is a need to eliminate any sagging between the elements.
- Adaptateur à utiliser - si nécessaire- en cas de montage des GRT709 sur châssis non Givi, pour éliminer les jeux entre les éléments.
- Adaptador a utilizar cuando se coloquen las GRT709 en soportes que no sean GIVI y sea necesario anular el juego entre los elementos.
- Adapter zur Montage der GRT709 auf einen Nicht-GIVI-Träger, damit ein Spielraum zwischen den Elementen vermieden wird.
- Adaptador para ser utilizado quando a bolsa GRT 709 for montada em suportes que não sejam da marca GIVI e seja necessário ajustar a folga entre os elementos.

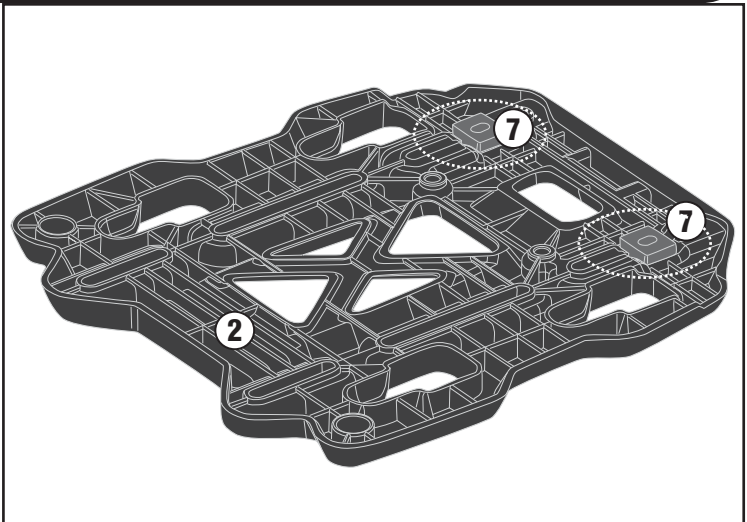
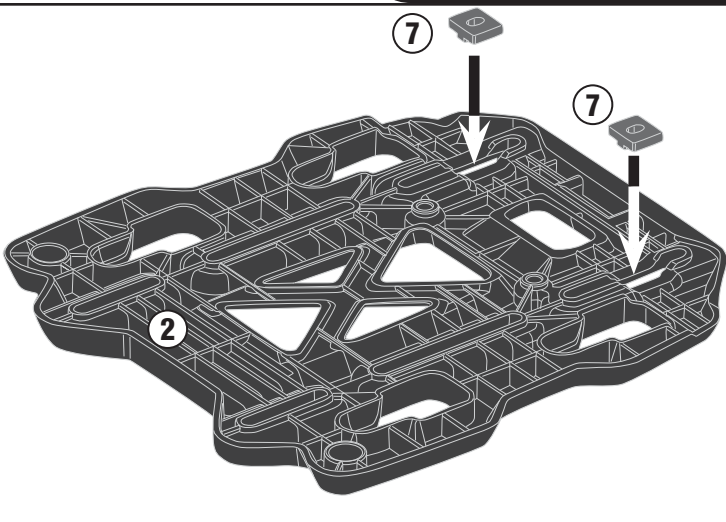

## OTHER FRAME (NOT GIVI)

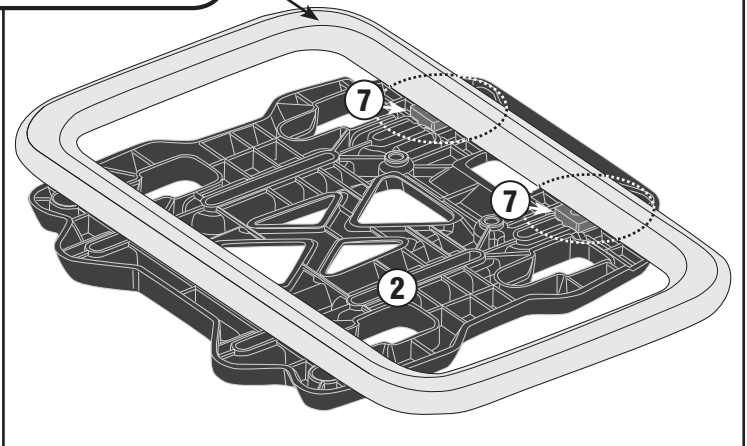
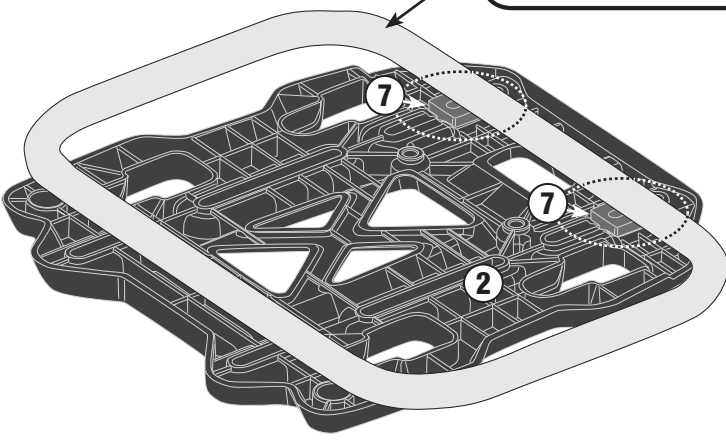

# GRT709

BORSE LATERALI 35+35LT - SIDE BAGS 35+35LTRS - SACOCHES LATÉRALES 35+35 LITRES SEITENTASCHEN MIT 35 + 35 LITER  
ALFORJAS LATERALES 35+35 LITROS - SACOS LATERAIS 35 + 35 LITRO

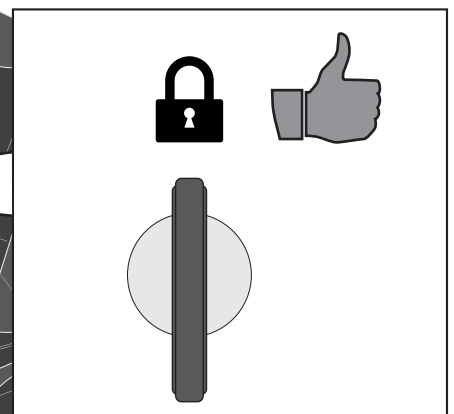
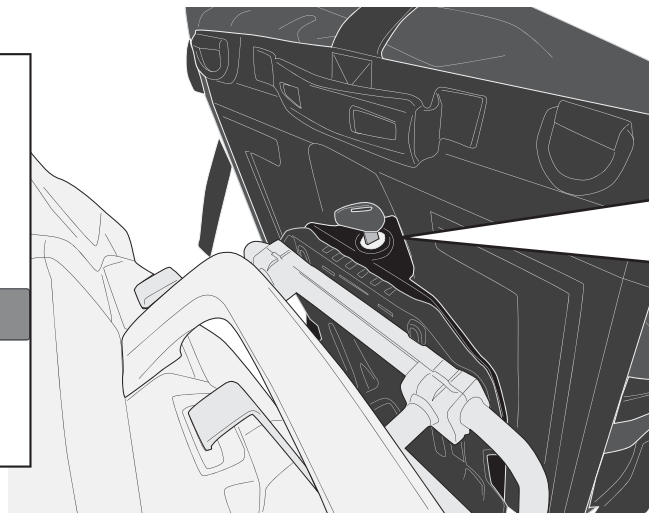
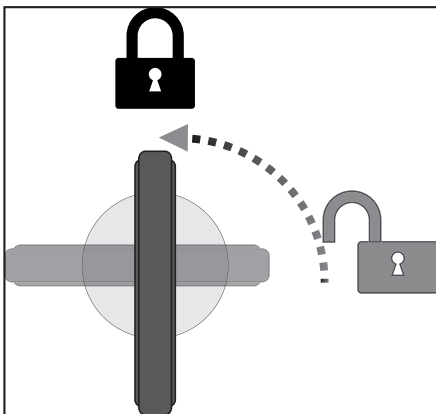
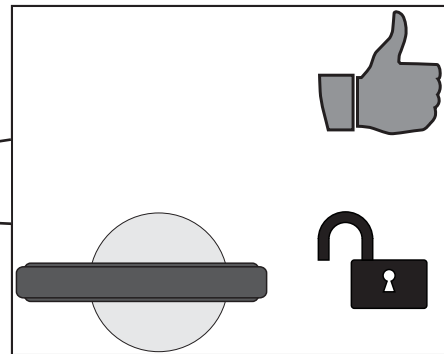
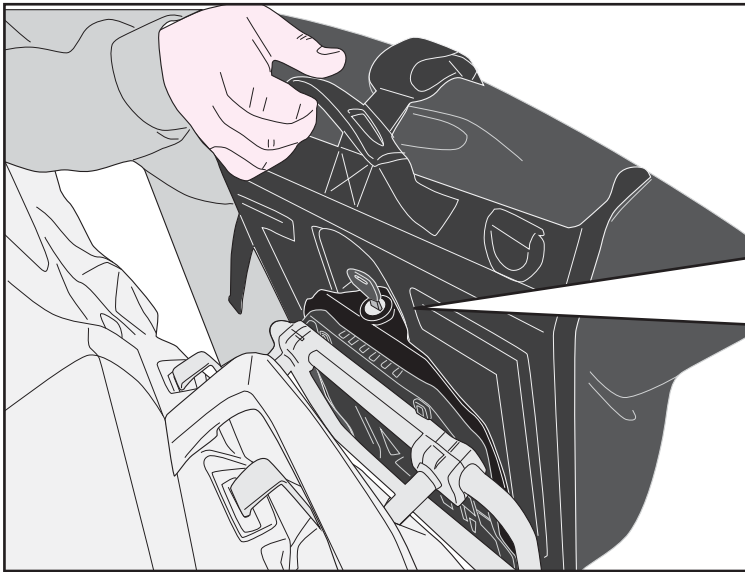
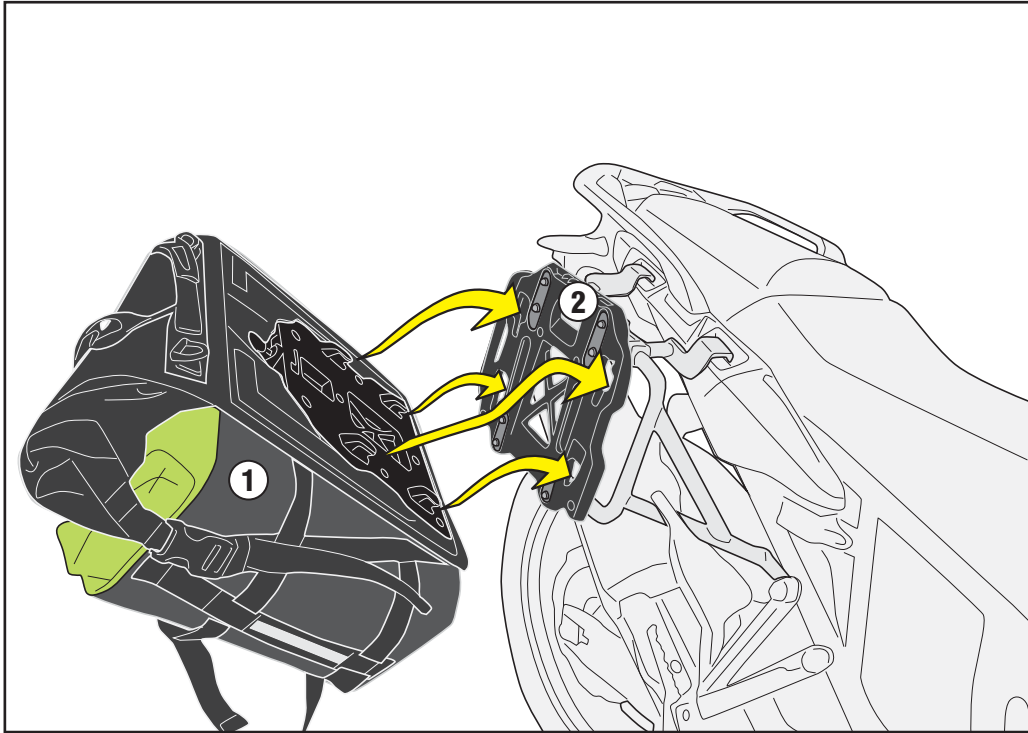

# GRT709

BORSE LATERALI 35+35LT - SIDE BAGS 35+35LTRS - SACOCHES LATÉRALES 35+35 LITRES SEITENTASCHEN MIT 35 + 35 LITER  
ALFORJAS LATERALES 35+35 LITROS - SACOS LATERAIS 35 + 35 LITRO

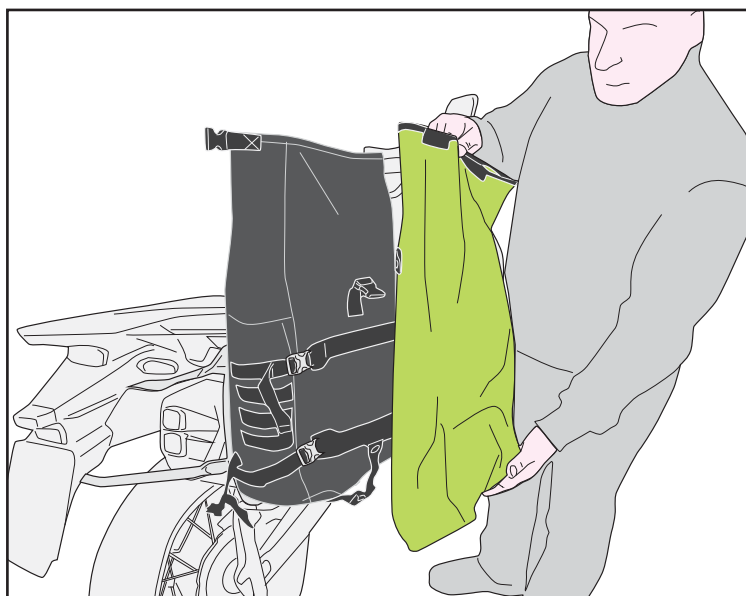
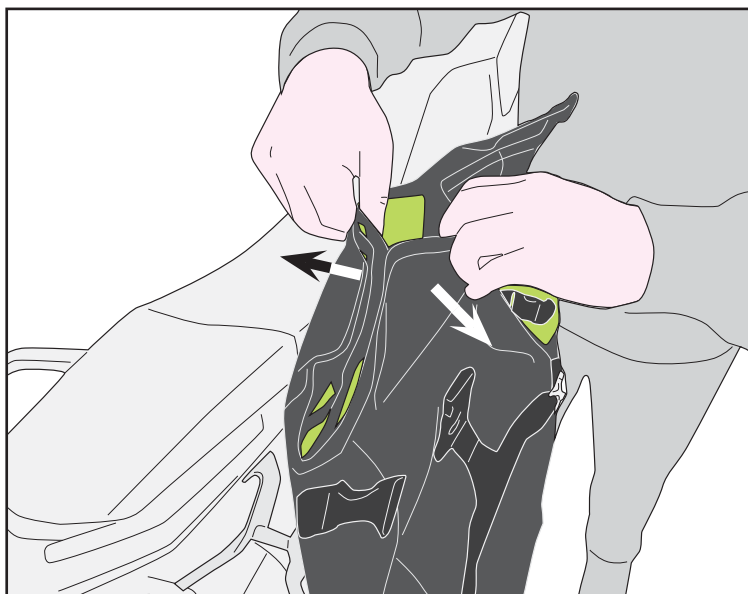
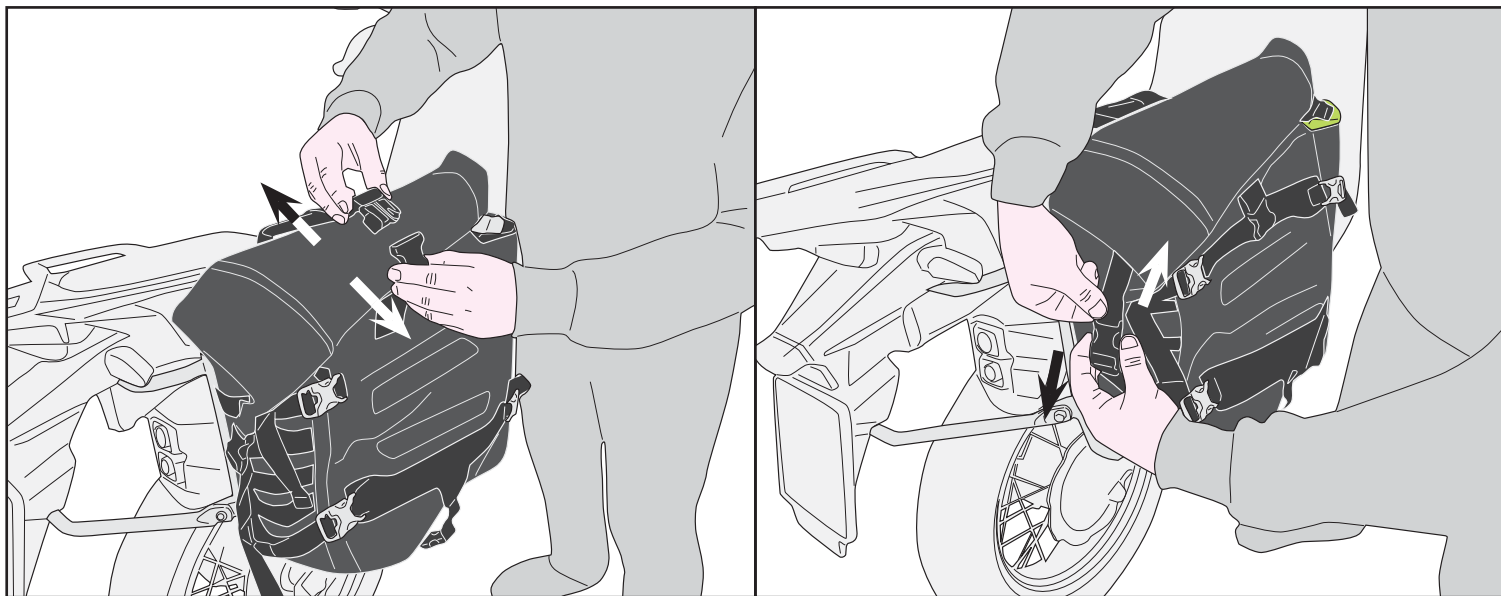

# GRT709

BORSE LATERALI 35+35LT - SIDE BAGS 35+35LTRS - SACOCHES LATÉRALES 35+35 LITRES SEITENTASCHEN MIT 35 + 35 LITER  
ALFORJAS LATERALES 35+35 LITROS - SACOS LATERAIS 35 + 35 LITRO

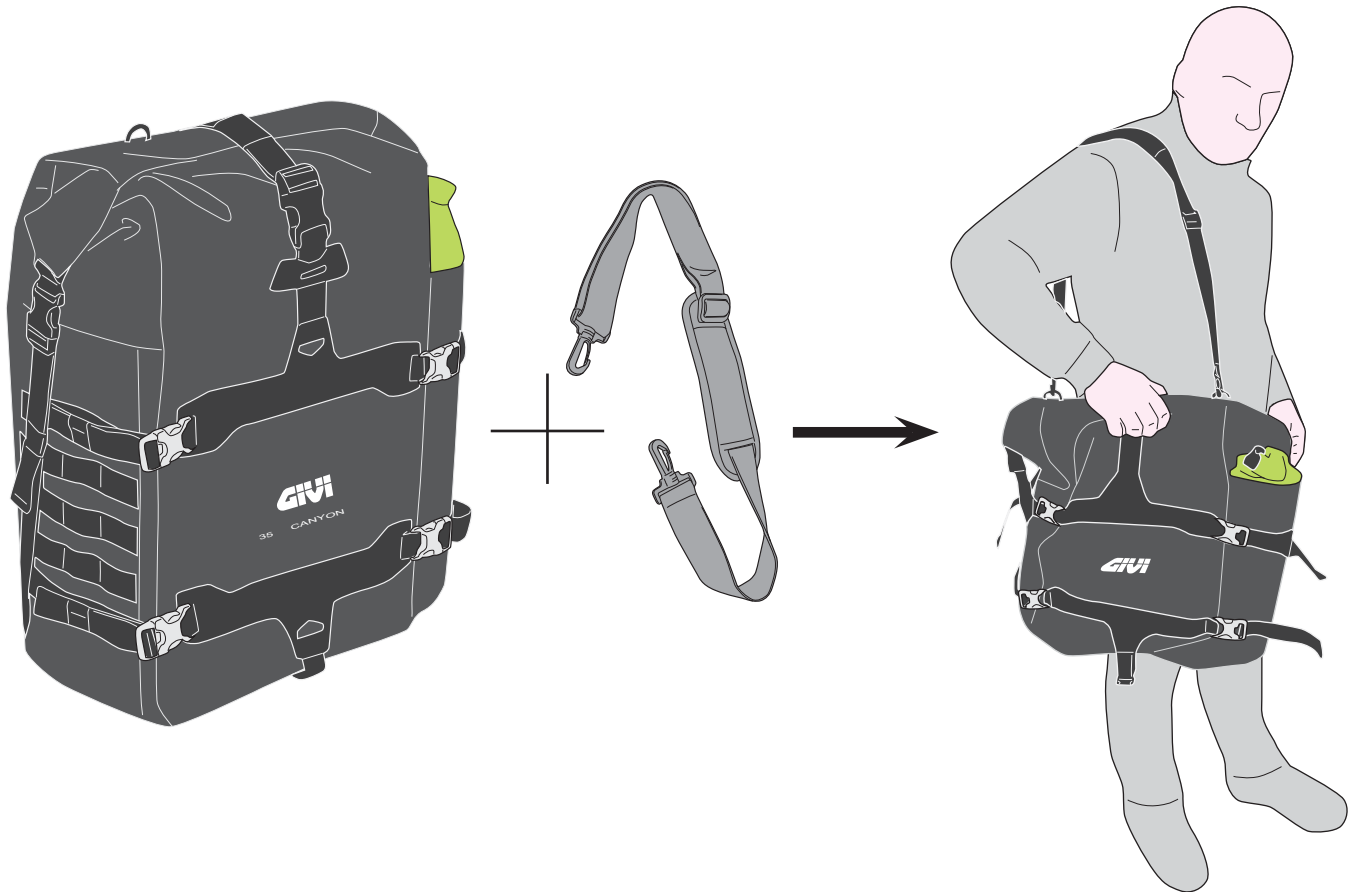
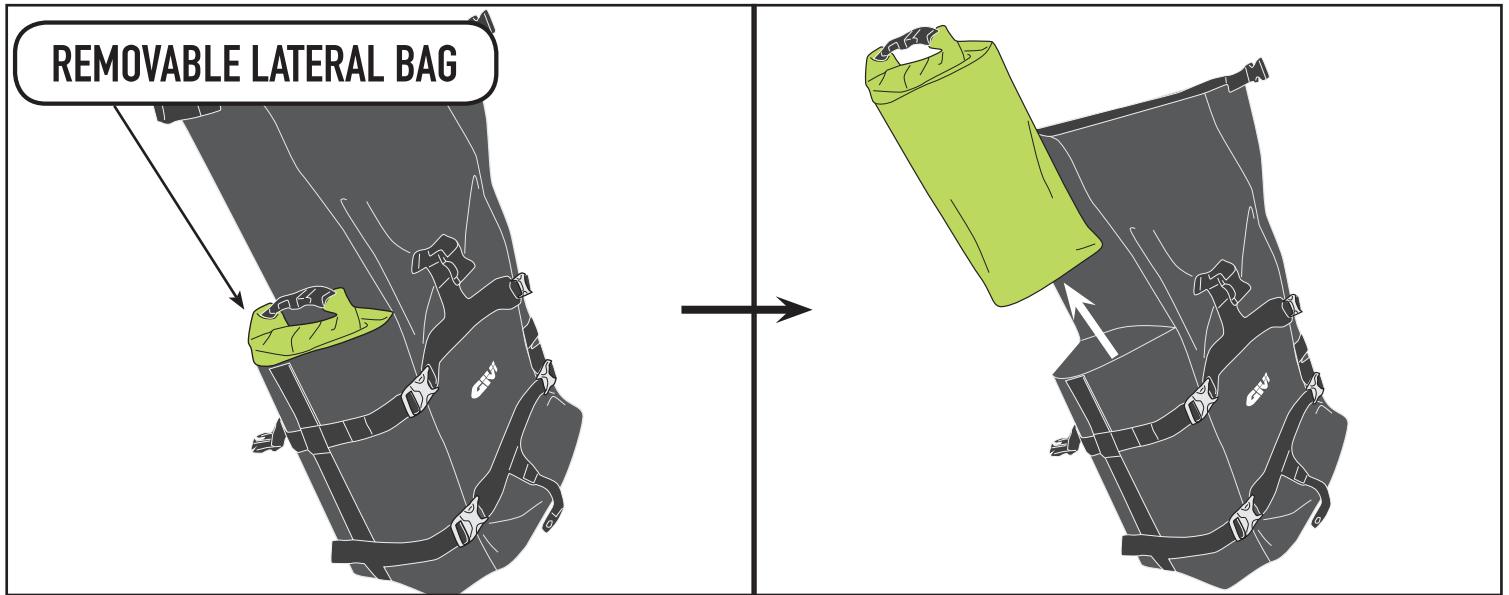

- ARROTOLARE PER 3 VOLTE SU SE STESSA L'APERTURA DELLA BORSA PER GARANTIRE L'IMPERMEABILITÀ
- TO ENSURE WATER RESISTANCE, IT IS ESSENTIAL TO ROLL DOWN THE OPENING OF THE BAG 3 TIMES
- ENROULER L'OUVERTURE DU SAC 3 FOIS SUR ELLE-MÊME AFIN D'ASSURER LA RÉSISTANCE À L'EAU
- UM ZU GARANTIEREN, DASS DIE TASCHE WASSERRESISTENT IST, IST ES NOTWENDIG DEN VERSCHLUSS 3X EINZUROLLEN.
- ENROLLAR 3 VECES SOBRE SÍ MISMA LA APERTURA DE LA BOLSA PARA GARANTIZAR LA IMPERMEABILIDAD.
- ENROLAR PARA 3 VEZES A ABERTURA DA BOLSA PARA GARANTIR A SUA IMPERMEABILIDADE

# GRT709

BORSE LATERALI 35+35LT - SIDE BAGS 35+35LTRS - SACOCHES LATÉRALES 35+35 LITRES SEITENTASCHEN MIT 35 + 35 LITER  
ALFORJAS LATERALES 35+35 LITROS - SACOS LATERAIS 35 + 35 LITRO

## MOLLE SYSTEM TOOLS

